

STEINER

TRIO PARK SP23

**2 Post, 2.5 Tonne (per level),
3 Level Parking Lift**



3 CAR PARKING LIFT



Ideal for:

Apartment buildings, property developers, private residences, dealerships and garages, car cert and storage centres are just some of the applications that prove the benefits of Steiner Parking Lifts.

Features:

- › Double hydraulic lifting cylinders, direct drive
- › Multiple parking heights
- › 100% laser cutting process for all parts and the whole structure
- › Preamsembled parts for easy installation
- › Effortless disassembly and relocation
- › Press-button operation box
- › Hydraulic overload protection
- › Enhanced anti-corrosion galvanized waving plates
- › Optional remote control
- › Customisable colours
- › 12-month warranty



If you are not 100% satisfied with your equipment, Treadway Equipped will repair, replace or refund the equipment free of charge within the first 100 days.

TRIO PARK SP23

**2 Post, 2.5 Tonne (per level),
3 Level Parking Lift**

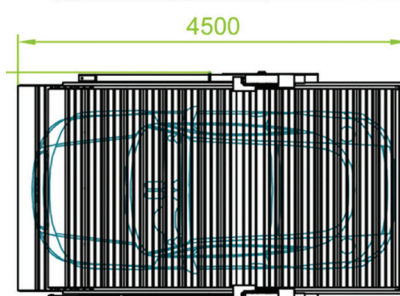
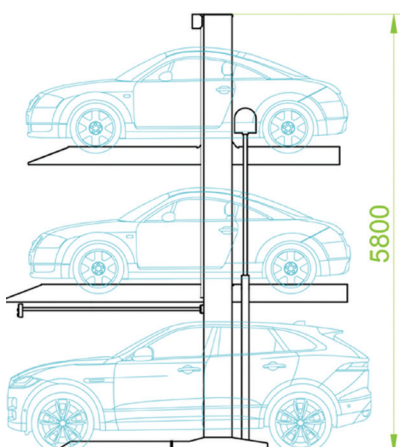
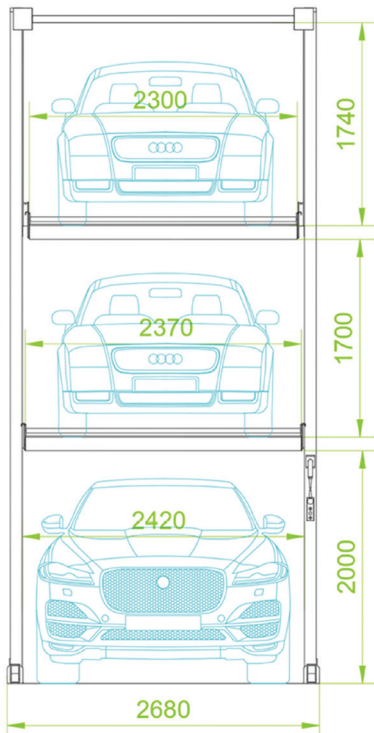

Safety System

- › Anti-Fall Hooks
- › Photocell Sensor
- › Limit Switches
- › Lock down button
- › Emergency Stop Button

SPECIFICATIONS

Lifting capacity	2,500 kg
Vehicle height	1,550-1,950 mm
Vehicle width	≤ 2,100 mm
Vehicle length	5,000 mm
Control box	Integrated modules for simple wiring
Power unit	3 kW hydraulic
Electrical requirements	Voltage; 3-phase
Control power	24V
Lifting speed	3 m/min



PARKING SYSTEMS

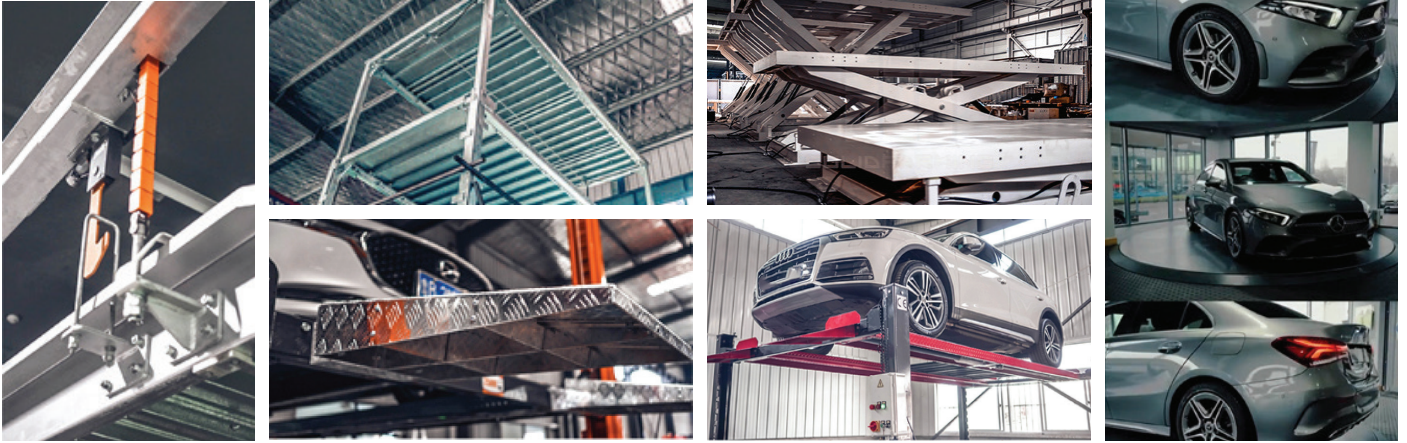

STEINER PARKING SYSTEMS

Treadway Equipped are transforming the way New Zealanders park to maximise valuable real estate.

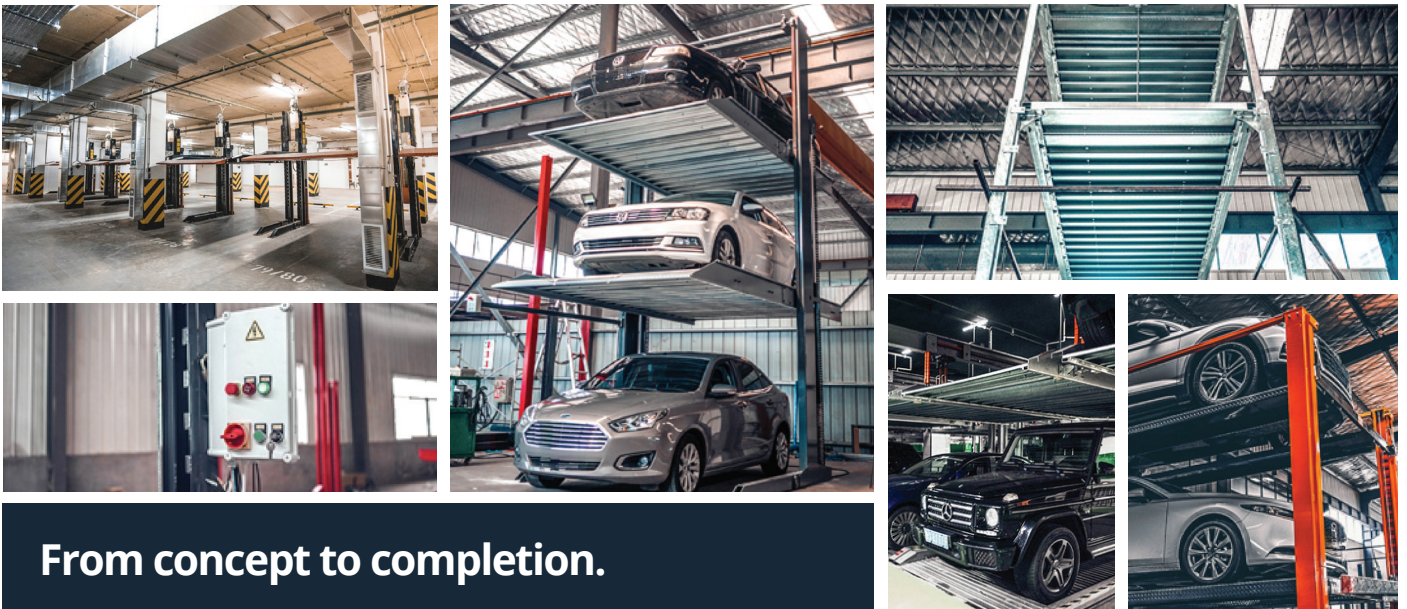

From concept to completion.



OUR PROMISE:

100

ONE HUNDRED DAYS
100% SATISFACTION

If you are not 100% satisfied with your equipment, Treadway Equipped will repair, replace or refund the equipment free of charge within the first 100 days.

0800 436 436
treadwayequipped.co.nz